

Modello

Posizione

Sx. (mm)

Dx. (mm)

STRAIGHT PULL

distanza flange	ant.	22,00	32,00
	post.	35,40	13,20
diametro flangia	ant.	22,00	22,00
	post.	22,00	56,00
offset	ant.	0,00	0,00
	post.	0,00	0,00

anteriore

posteriore

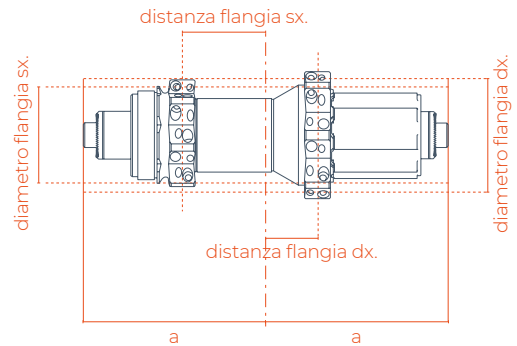
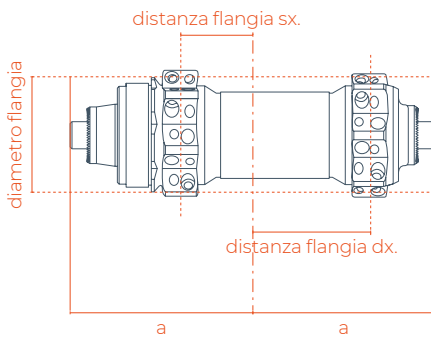

STRAIGHT PULL BOOST

distanza flange	ant.	27,00	37,00
	post.	38,40	16,30
diametro flangia	ant.	22,00	22,00
	post.	22,00	56,00
offset	ant.	0,00	0,00
	post.	0,00	0,00

anteriore

posteriore

